

GO-TRACT™ 1200

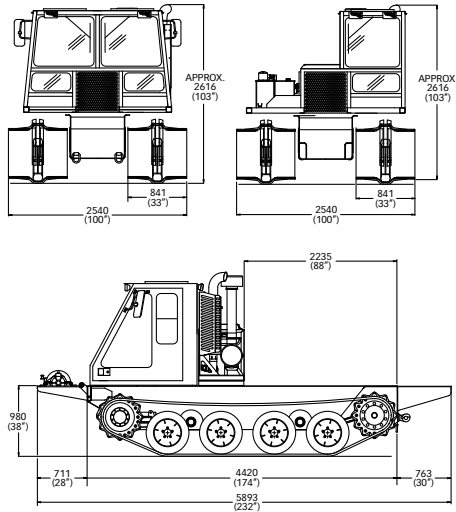

Pinotti



EPA-CERTIFIED

The EPA-certified Perkins engine is installed, tested and certified in conjunction with the entire vehicle. PRINOTH's commitment to exceptional quality results in this utility vehicle line-up that meets EPA Tier 3 standards.



The color gray is used only for illustration purposes.

DIMENSIONS

Overall length without extension	4 420 mm	174 in
Overall width	2 540 mm	100 in
Overall height	2 616 mm	103 in
Ground clearance	381 mm	15 in

PERFORMANCE

Curb weight (basic vehicle)	5 375 kg	11 850 lb
Payload	5 443 kg	12 000 lb
Maximum speed	15 km/h	9.3 mph
Fording depth	965 mm	38 in
Turning radius	0 m	0 in
Ground pressure (with 33 in tracks)	no penetration	6 in penetration
Basic vehicle	141 g/cm ² (2 psi)	105 g/cm ² (1.49 psi)
Loaded vehicle	285 g/cm ² (4.05 psi)	213 g/cm ² (3.03 psi)
Maximum gradeability		
Uphill / downhill	60%	31°
Sidehill	40%	21.8°

ENGINE

Make	Perkins	
Model	1106D	
Type	Turbo diesel, electronic fuel system, EPA Tier 3 and EU Stage IIIA.	
Number of cylinders	6	
Displacement	6.6 L	403 in ³
Power @ 2 200 rpm	117 kW	157 hp
Torque @ 1 400 rpm	641 N·m	473 lb·ft

TRANSMISSION

	Make	Type
Pump drive	Funk	Triple pad
Hydrostatic pumps	Sauer-Danfoss	Axial, variable displacement
Hydrostatic motors	Sauer-Danfoss	Axial, fixed displacement
Planetaries	Oerlikon Fairfield	

CONTROL

Type	Microcontroller with color display
Inputs	Steering wheel, progressive front - neutral - reverse lever and speed pedal
Outputs	Independent control of each track
Other features	Anti-stall

ELECTRICAL

Type	12 V
Alternator	120 A
Battery capacity	2 X 950 CCA

SUSPENSION

Type	Walking beam
------	--------------

WHEELS

Quantity	8	
Type	Solid	
Dimensions	134 mm x 610 mm	5.25 in x 24 in

TRACKS

Type	D-dent, hardened steel	
Width	838 mm	33 in
Belt	Rubber, 5-ply	
Tensioner	Grease-filled cylinder	

CHASSIS

Type	Tub	
Drain plug	Yes	
Access panels	Yes	

CAPACITIES

Cooling system	28 L	7.5 US gal
Fuel tank	210 L	55.5 US gal
Hydrostatic tank	81 L	21.4 US gal

PROVISION FOR EXTRA HYDRAULIC PUMP

Location	Top pad on triple pump drive
Flange type	SAE B - 4 in dia. pilot
Shaft type	SAE B - 13 teeth, 16/32 pitch
Direction of rotation	CCW (when looking at pump shaft)
Max rotational speed	3 390 rpm

OPTIONAL EQUIPMENT

- One-person or two-person cab
- Heavy duty brushguards
- Rear pintle hook
- External mirrors (heated available)
- Rear wiper and washer
- Amber beacon light
- Remote controlled directional spotlight
- Electronic inclinometer
- Air conditioning for two-person cab
- Arctic package
- Front and rear extensions
- Dump box
- Winch
- Blade
- High flow hydraulic capabilities for: drills, cranes, knuckle booms, man lifts, digger derricks, backhoes and many accessories

©2009 PRINOTH Ltd. All rights reserved. ® and TM are trademarks of PRINOTH Ltd. PRINOTH Ltd. reserves the right to change or discontinue any specifications, designs, features, models or accessories shown or indicated without notice.

