

GO-TRACT™ 2000

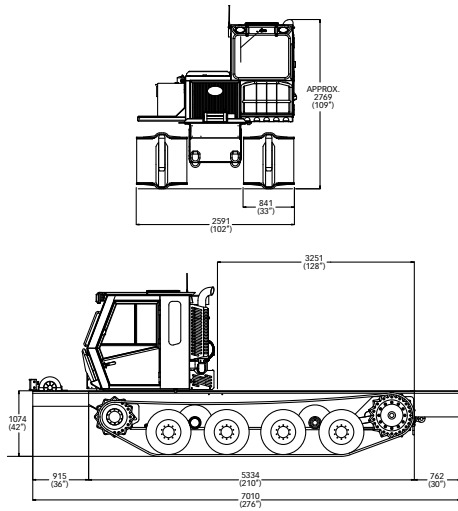

Pinotti



EPA-CERTIFIED

The EPA-certified Caterpillar engine is installed, tested and certified in conjunction with the entire vehicle. PRINOTH's commitment to exceptional quality results in this utility vehicle line-up that meets EPA Tier 3 standards.



DIMENSIONS

Overall length without extension	5 334 mm	210 in
Overall width	2 591 mm	102 in
Overall height	2 769 mm	109 in
Ground clearance	442 mm	17 in

PERFORMANCE

Curb weight (basic vehicle)	9 130 kg	20 128 lb	
Payload	9 072 kg	20 000 lb	
Maximum speed	8.6 km/h	5.3 mph	
Fording depth	1 067 mm	42 in	
Turning radius	0 m	0 in	
Ground pressure (with 33 in tracks)	no penetration	6 in penetration	
	Basic vehicle	182 g/cm ² (2.59 psi)	141 g/cm ² (2.01 psi)
	Loaded vehicle	363 g/cm ² (5.16 psi)	281 g/cm ² (4.00 psi)
Maximum gradeability	Uphill / downhill	60%	31°
	Sidehill	40%	21.8°

ENGINE

Make	Caterpillar	
Model	C-7	
Type	Turbo diesel, electronic fuel system, EPA Tier 3 and EU Stage IIIA.	
Number of cylinders	6	
Displacement	7.24 L	442 in ³
Power @ 2 200 rpm	187 kW	250 hp
Torque @ 1 400 rpm	1 142 N·m	842 lb·ft

TRANSMISSION

	Make	Type
Pump drive	Funk	Triple pad
Hydrostatic pumps	Sauer-Danfoss	Axial, variable displacement
Hydrostatic motors	Sauer-Danfoss	Axial, fixed displacement
Planetaries	Bonfiglioli Trasmital	

CONTROL

Type	Microcontroller with color display
Inputs	Steering wheel, progressive front - neutral - reverse lever and speed pedal
Outputs	Independent control of each track
Other features	Anti-stall

ELECTRICAL

Voltage	12 V
Alternator	115 A
Battery capacity	2 X 950 CCA

SUSPENSION

Type	Walking beam
------	--------------

WHEELS

Quantity	8
Type	Solid
Dimensions	650 X 16

TRACKS

Type	Hardened steel with rubber belt
Width	838 mm 33 in
Belt	Rubber, 6-ply
Tensioner	Grease-filled cylinder

CHASSIS

Type	Tub
Drain plug	Yes
Access panels	Yes

CAPACITIES

Cooling system	27 L	7 US gal
Fuel tank	350 L	92 US gal
Hydrostatic tank	63 L	16 US gal

PROVISION FOR EXTRA HYDRAULIC PUMP

Location	Top pad on triple pump drive
Flange type	SAE B - 4 in dia. pilot
Shaft type	SAE B - 13 teeth, 16/32 pitch
Direction of rotation	CCW (when looking at pump shaft)
Max rotational speed	3 390 rpm

OPTIONAL EQUIPMENT

- One-person or two-person cab
- Heavy duty brushguards
- Rear pintle hook
- External mirrors (heated available)
- Amber beacon light
- Remote controlled directional spotlight
- Electronic inclinometer
- Air conditioning
- Arctic package
- Front and rear extensions
- Winch
- Blade
- High flow hydraulic capabilities for: drills, cranes, knuckle booms, man lifts, digger derricks and backhoes
- 3rd battery available

©2009 PRINOTH Ltd. All rights reserved. ® and TM are trademarks of PRINOTH Ltd. PRINOTH Ltd. reserves the right to change or discontinue any specifications, designs, features, models or accessories shown or indicated without notice.

