

GO-TRACT™ 4500

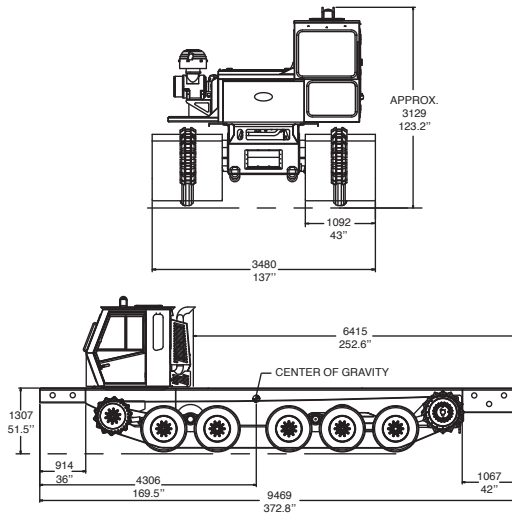

Pinotti



EPA-CERTIFIED

The EPA-certified Caterpillar engine is installed, tested and certified in conjunction with the entire vehicle. PRINOTH's commitment to exceptional quality results in this utility vehicle line-up that meets EPA Tier 3 standards.



DIMENSIONS

Overall length without extension	7 488 mm	295 in
Overall width	3 480 mm	137 in
Overall height	3 043 mm	119.8 in
Ground clearance	533 mm	21 in

PERFORMANCE

Curb weight (basic vehicle)	16 330 Kg	36 000 lb
Payload	19 050 Kg	42 000 lb
Maximum speed	9.6 km/h	6.0 mph
Fording depth	1321 mm	52 in
Turning radius	0 m	0 ft

Ground pressure (no penetration)

Basic vehicle	162 g/cm ²	2.31 psi
Loaded vehicle	352 g/cm ²	5.00 psi

Ground pressure (6 in. Penetration)

Basic vehicle	139 g/cm ²	1.97 psi
Loaded vehicle	300 g/cm ²	4.27 psi

Gradeability

Uphill / Downhill	60%	31.0°
Sidehill	40%	21.8°

ENGINE

Make	Caterpillar	
Model	C-9	
Type	Turbo diesel, electronic fuel system	
Emission Standard	EPA Tier 3 and EU Stage IIIA.	
Number of cylinders	6	
Displacement	8.8 L	537 in ³
Power @ 2200 RPM	280 kW	375 HP
Torque @ 1400 RPM	1 668 N•m	1 230 lb•ft

TRANSMISSION

	Make	Type
Pump drive	Funk	Triple pads
Hydrostatic pumps	Sauer-Danfoss	Axial, variable displacement
Hydrostatic motors	Bosch-Rexroth	Axial, variable displacement
Planetaries	Oerlikon Fairfield	

CONTROL

Type	Microcontroller with color display
Inputs	Steering wheel, progressive forward-neutral-reverse lever and speed pedal
Outputs	Independent control of each track
Other feature	Anti-stall

ELECTRICAL

Voltage	12 V
Alternator	140 A
Battery capacity	3 X 950 CCA

SUSPENSION

Type	Walking beam
------	--------------

WHEELS

Quantity	10
Type	Solid
Dimensions	8.25 X 20

TRACKS

Type	D-Dent, Hardened Steel	
Width	1 092 mm	43 in
Belt	Rubber, 7-ply	
Tensioner	Cylinder filled with grease	

CHASSIS

Type	Tub
Drain plug	Yes
Access panels	Yes

CAPACITIES

Cooling system	38 L	10 US gal
Fuel tank	455 L	120 US gal
Hydrostatic tank	63 L	16 US gal

PROVISION FOR EXTRA HYDRAULIC PUMP

Location	Top pad on triple pump drive
Flange type	SAE B - 4 in dia. pilot
Shaft type	SAE B - 13 teeth, 16/32 pitch
Direction of rotation	CCW (when looking at pump shaft)
Max rotational speed	3 058 rpm

OPTIONAL EQUIPMENT

- One-person or two-person cab
- Heavy duty brushguards
- Rear pintle hook
- External mirrors (heated available)
- Amber beacon light
- Remote controlled directional spotlight
- Electronic inclinometer
- Air conditioning
- Front and rear extensions
- Winch
- Arctic package
- High flow hydraulic capabilities for: drills, cranes, knuckle booms, man lifts, digger derricks, backhoes and many accessories

©2009 PRINOTH Ltd. All rights reserved. ® and TM are trademarks of PRINOTH Ltd. PRINOTH Ltd. reserves the right to change or discontinue any specifications, designs, features, models or accessories shown or indicated without notice.

