



Subject: NEW PRODUCT RELEASE
Durabuilt™ 3500 and 5500 Series Improvements for Challenger MT700 and MT800 Tracks



Today's Challenger MT700 and MT800 rubber-tracked tractors feature higher speed, greater versatility and more power than previous generations of tracked tractor. Because of their ability to put more horsepower to the ground, these machines have seen tremendous growth in demanding high load, high torque applications.

The result of extensive development and testing, Camoplast is pleased to announce enhancements to our product offering for the Challenger MT700 and MT800 line. These new and improved tracks have been specifically engineered for real-world conditions. Load carrying main cables have been increased in diameter for greater tear strength. Rubber plies have been added to the ID for better puncture resistance.

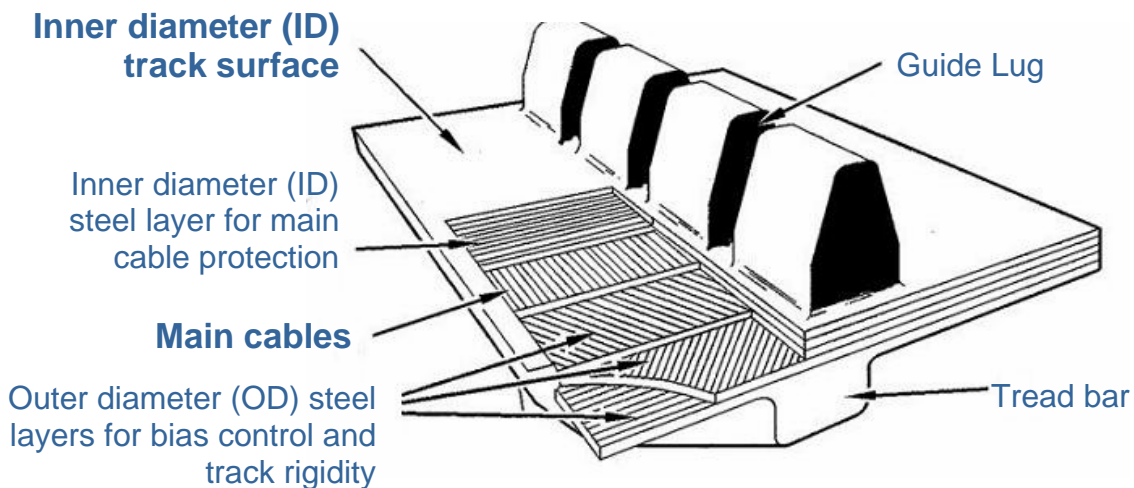

When coupled with the other construction features of the Durabuilt™ track, quality and life are maximized. Due to the mixed use nature of the tractors we are eliminating the old part numbers when existing stocks are depleted.



Ag Aftermarket
PRODUCT INFORMATION BULLETIN 2006-004

FEATURES AND BENEFITS

- All 3500 series tracks now include the large 5.3 mm diameter main cables along with a thicker carcass to improve tear strength and ID puncture resistance in general agricultural applications.
- All 5500 series tracks for extreme agricultural and construction applications now include the large diameter main cables and a thicker carcass with more material added to the ID to provide improved ID puncture resistance and protection from track tearing.

NEW PART NUMBERS

| Challenger MT 700 (348") | | | | |
|---------------------------------|--------------|-----------------------|-----------------|-------------------------|
| Width (inches) | Track Series | Durabuilt Part Number | OEM Part Number | Comments |
| 14.5 RH | 5500 | 655-1408 | 508600D1 | New - replaces 655-1400 |
| 14.5 LH | 5500 | 655-1409 | 508601D1 | New - replaces 655-1401 |
| 16.5 RH | 3500 | 635-1625 | 508602D1 | New - replaces 635-1609 |
| 16.5 LH | 3500 | 635-1626 | 508603D1 | New - replaces 635-1610 |
| 16.5 RH | 3500 | 695-1623 | | New - replaces 695-1611 |
| 16.5 LH | 3500 | 695-1624 | | New - replaces 695-1612 |
| 16.5 RH | 5500 | 655-1621 | 508606D1 | New - replaces 655-1613 |
| 16.5 LH | 5500 | 655-1622 | 508607D1 | New - replaces 655-1614 |
| 18 | 3500 | 635-1815 | | New - replaces 635-1807 |
| 18 | 3500 | 695-1818 | | New - replaces 695-1810 |
| 18 | 5500 | 655-1817 | | New - replaces 655-1809 |
| 20 | 3500 | 635-2004 | | New - replaces 635-2002 |
| 20 | 5500 | 655-2005 | | New - replaces 655-2003 |
| 25 | 3500 | 635-2521 | | New - replaces 635-2512 |
| 25 | 3500 | 695-2520 | | New - replaces 695-2511 |
| 25 | 5500 | 655-2522 | | New - replaces 655-2513 |
| 25 | 5500 | 655-2523 | | New - replaces 655-2514 |
| 30 | 3500 | 635-3028 | | New - replaces 635-3013 |
| 30 | 5500 | 655-3030 | | New - replaces 655-3015 |
| Challenger MT 800 (392") | | | | |
| 18 | 5500 | 656-1816 | 508608D1 | New - replaces 656-1808 |
| 27.5 | 3500 | 636-2708 | | New - replaces 636-2703 |
| 27.5 | 5500 | 656-2707 | | New - replaces 656-2704 |
| 30 | 3500 | 636-3029 | | New - replaces 636-3014 |
| 30 | 5500 | 656-3031 | | New - replaces 656-3016 |
| 36 | 3500 | 636-3621 | | New - replaces 636-3603 |
| 36 | 5500 | 656-3622 | | New - replaces 656-3604 |

Pricing to follow separately.